



Santa Maria College
PHYSICS Year 12
Stage 3A 3B

Semester 2 Examination 2010
Thursday 30th September (am)

Question/Answer Booklet



Time allowed for this paper

Reading time before commencing work: ten minutes
Working time for paper: three hours

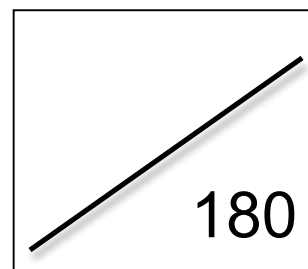

Materials required/recommended for this paper

To be provided by the supervisor

This Question/Answer Booklet
Formulae and Constants Sheet

To be provided by the candidate

Standard items: pens, pencils, eraser, correction fluid, ruler, highlighters

Special items: non-programmable calculators satisfying the conditions set by the Curriculum Council for this course, drawing templates, drawing compass and a protractor

Important note to candidates

No other items may be taken into the examination room. It is **your** responsibility to ensure that you do not have any unauthorised notes or other items of a non-personal nature in the examination room. If you have any unauthorised material with you, hand it to the supervisor **before** reading any further.

Structure of this paper

Section	Number of questions available	Number of questions to be answered	Suggested working time (minutes)	Marks available	Percentage of exam
Section One: Short response	13	13	45	49	27
Section Two: Problem-solving	8	8	95	95	53
Section Three: Comprehension	2	2	40	36	20
					100

Instructions to candidates

1. The rules for the conduct of Western Australian external examinations are detailed in the *Year 12 Information Handbook 2010*. Sitting this examination implies that you agree to abide by these rules.
2. Write answers in this Question/Answer Booklet.
3. You must be careful to confine your responses to the specific questions asked and to follow any instructions that are specific to a particular question.
4. Working or reasoning should be clearly shown when calculating or estimating answers.
5. Spare pages are included in this booklet. They can be used for planning your responses and/or as additional space if required to continue an answer.
 - Planning: If you use the spare pages for planning, indicate this clearly at the top of the page.
 - Continuing an answer: If you need to use the space to continue an answer, indicate in the original answer space where the answer is continued, i.e. give the page number. Fill in the number of the question(s) that you are continuing to answer at the top of the page.

Section One: Short response

27% [49 Marks]

This section has **13** questions. Answer **all** questions. Write your answers in the space provided.

Suggested working time for this section is 45 minutes.

Question 1

[3 marks]

A positively charged metal sphere is located above a negatively charged conducting plate as shown in the diagram. Sketch the electric field lines between the charged sphere and the plate, using the four dots on the sphere as starting points.

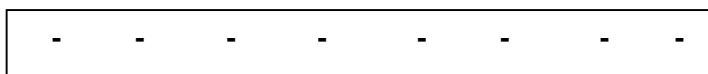
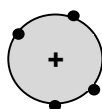

Question 2

[3 marks]

Water waves move slower in shallower water than in deep water. This slowing down of waves is the cause of breaking waves. Complete the diagram below to show the accurate shape and pattern of waves coming into shore at an angle as they move from the deep to the shallower water near the beach. Draw in 4 more waves on the diagram below as they move through the shallow water.

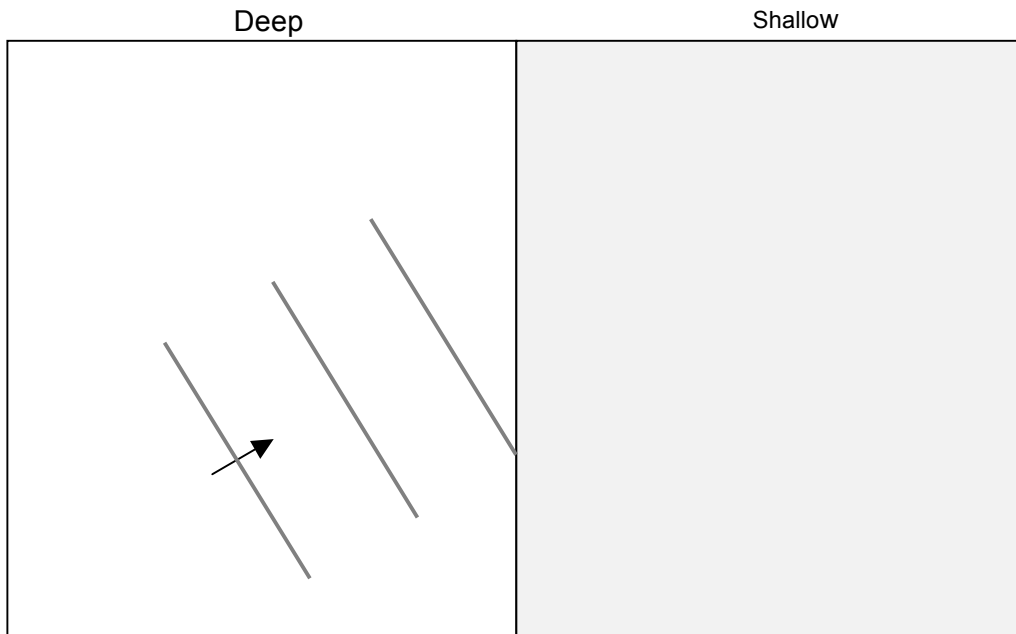

Question 3

[5 marks]

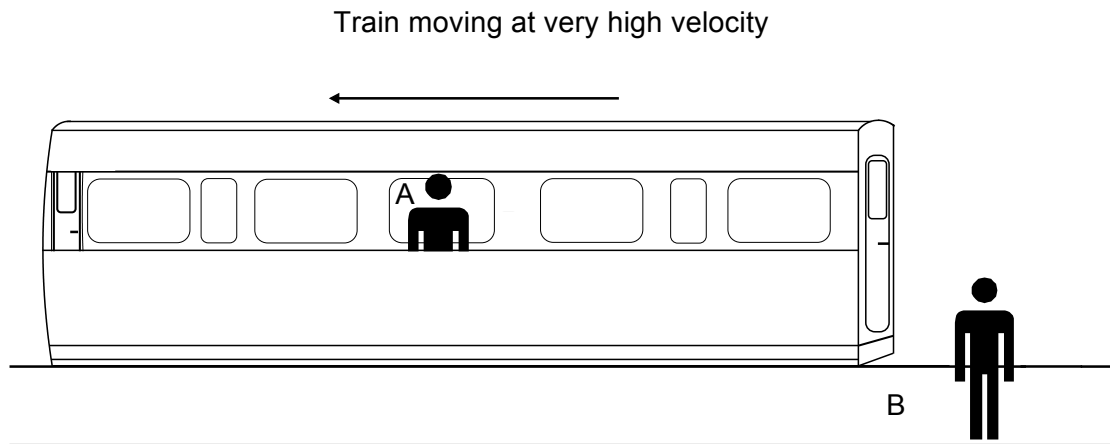

An observer at position A at the midpoint of a train carriage (a moving frame of reference), sends light signals to the front and back of the carriage at the same time. These light beams open doors at each end of the carriage. Another observer at position B is stationary on the platform, watching the train moving away from him at high velocity.

- a) Does observer A see the doors in the carriage open simultaneously, or at different times?
[1 mark]

- b) Does observer B see the doors in the carriage open simultaneously, or at different times?
[2 marks]

- c) If the observations are different, whose observation is correct? Explain your reasoning.
[2 marks]

Question 4

[4 marks]

In an experiment two metal plates are attached to a 500 V power supply to produce an electric field E between the plates.

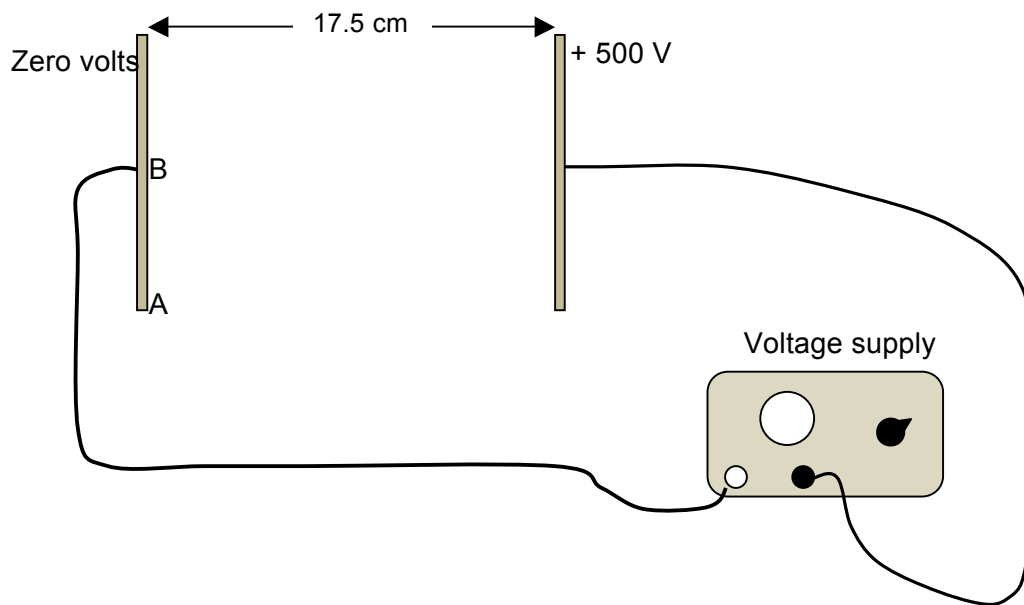

a) Calculate a value for E when the plates are placed 17.5 cm apart. [2 marks]

b) Two electrons are released at points A and B on the left hand plate which are attracted towards the right hand plate. Draw in on the diagram the paths of each of these electrons as they move from left to right. [2 marks]

Question 5

[3 marks]

A spaceship travelling at 20% of the speed of light (i.e. $0.2 \times c$) contains a cube shaped box.

An astronaut floating freely in space outside the spaceship views the box through a window as the spaceship passes and records its dimensions as L , W and H .

A passenger on the spaceship records the dimensions of the box as L_0 , W_0 and H_0 .

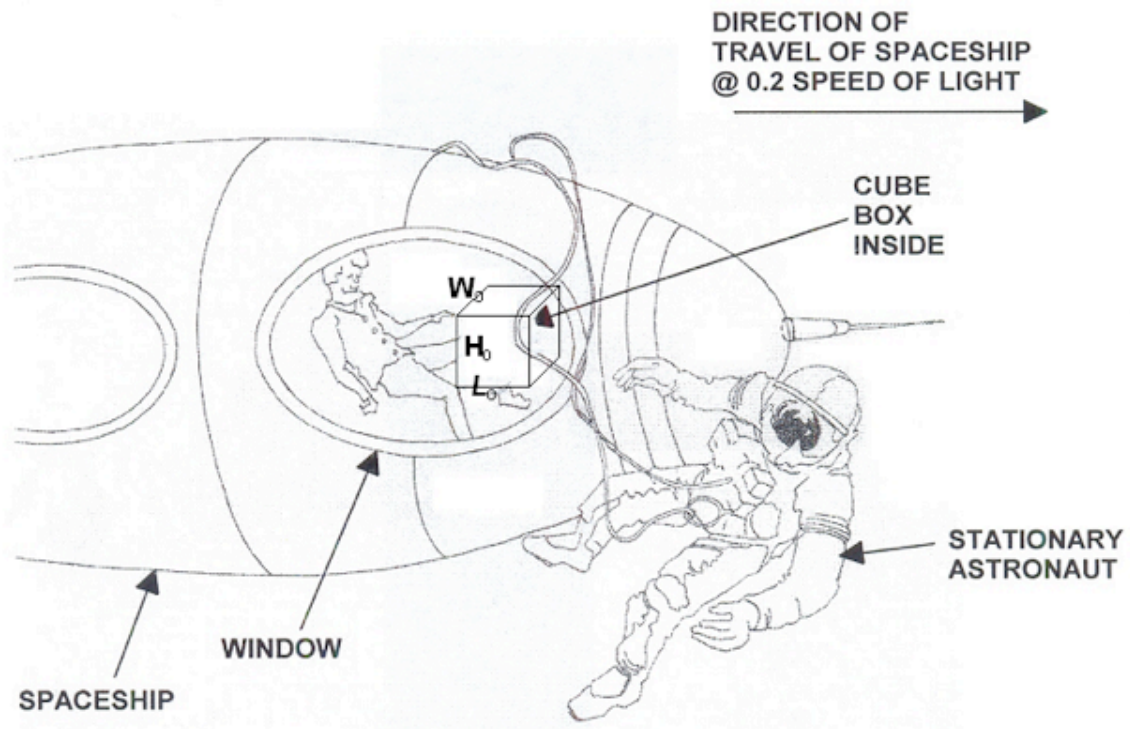

(a) Which of the following options best describes the dimensions of the box as observed by the astronaut outside the spaceship compared to the measurements made by the passenger?

- A. $L < L_0$, $W < W_0$, $H = H_0$
- B. $L > L_0$, $W = W_0$, $H = H_0$
- C. $L < L_0$, $W = W_0$, $H = H_0$
- D. $L < L_0$, $W < W_0$, $H < H_0$

Answer _____

[1 mark]

(b) Explain why you selected your answer.

[2 marks]

Question 6**[4 marks]**

The force that holds the protons and neutrons together in the nucleus is known as the strong nuclear force. This force only acts on particles known as hadrons of which protons and neutrons are members. Hadrons are thought to be made up of quarks having non integer charges. All hadrons are made of three quarks.

These quarks have different charges. The up quark has a charge of $+\frac{2}{3}e$ while the down quark has a charge of $-\frac{1}{3}e$. 'e' is the charge on an electron.

(a) List the quarks in a proton and justify your answer. (2 marks)

(b) List the quarks in a neutron and justify your answer. (2 marks)

Question 7**[3 marks]**

A light-emitting diode (LED) can run at a safe voltage of 2.0 V and yet it can be connected effectively into a 12 volt circuit if a series resistor is used.

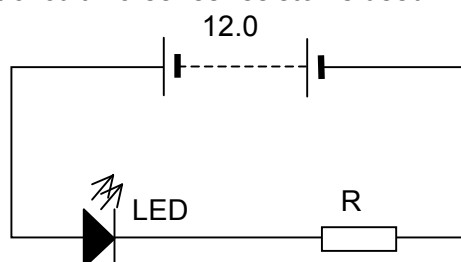

The circuit above shows an LED connected correctly into a 12 volt circuit.

If the LED must not carry a current exceeding 10.0 mA, calculate the value of the resistor R to be used.

Question 8**[4 marks]**

A picture of mass 4.20 kg is hung from a nail in the wall by a wire, as shown in Figure 1. If the wire makes an angle of 35° to the picture, calculate the tension in the wire.

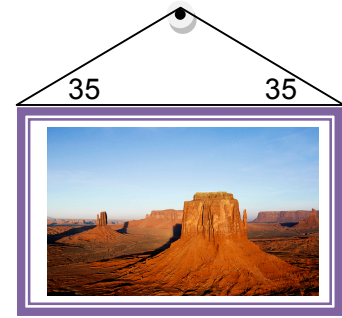
**Question 9****[3 marks]**

The planet Tedja has been discovered in another galaxy which could possibly have conditions to support life as we know it *if* its gravitational field strength is large enough to attract and hold molecules of oxygen, which is estimated to be $> 5.6 \text{ N kg}^{-1}$.

If the radius of the planet is 0.85 times Earth's radius and its mass is 0.34 times Earth's mass, calculate a value for 'g' on the surface of Tedja and state whether it is likely to be able to support life.

Question 10

[3 marks]

Galileo set up a “thought” experiment where a ship was moving to the right with a constant velocity and a sailor, who was sitting at the top of the mast, dropped a cannon ball. He asked the question as to where this cannon ball would land as it hit the deck.

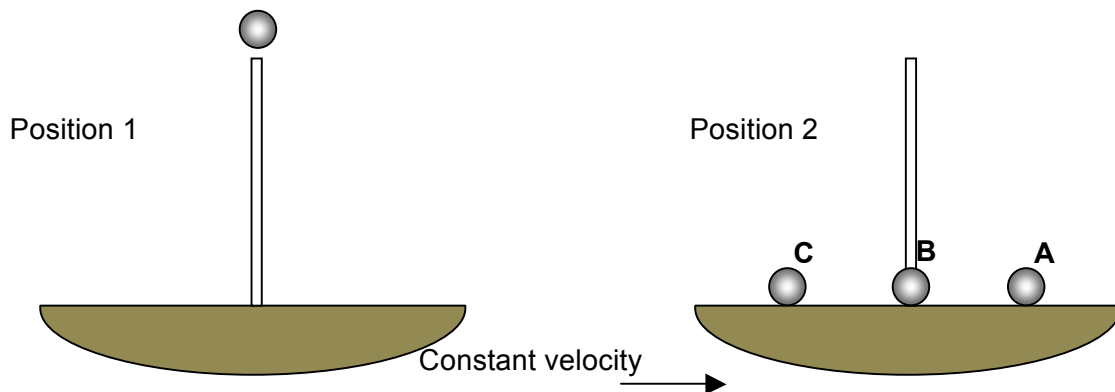

a) Circle the point where you think the ball will land in position 2:

A B C

[1 mark]

b) Explain your choice of answer to part a).

[2 marks]

Question 11**[3 marks]**

What is the maximum speed a 30 tonne truck can corner a bend with a radius of curvature of 200m if the curve is banked at 10° to the horizontal and there is no friction force?

Question 12**[6 marks]**

Aircraft flying through the Earth's magnetic field are subject to an induced EMF across the wings.

a) At which places on Earth will the aircraft experience the maximum induced EMF?

[1 mark]

b) If the maximum magnitude of the Earth's magnetic field is 5.00×10^{-5} T, calculate the magnitude of the EMF that would be induced across the wings of a Boeing 747 flying at its maximum speed. A Boeing 747 wing span is about 60 m and its maximum speed is about 900 km h^{-1} .

[3 marks]

c) Would it be realistic for the induced EMF produced in this way to be used to power appliances on board the aircraft? Justify your answer.

[2 marks]

Question 13**[5 marks]**

Small computers mounted on bicycles measure the speed and distance a rider has achieved on a ride. A permanent magnet is attached to a spoke in the front wheel and a coil is mounted on the front fork of the bicycle. A wire connects the coil to a small computer on the handlebars which provides a read out of the bicycle's speed and distance. When the computer is first used the rider programs into it the circumference of the wheel. The diagram below shows the arrangement.

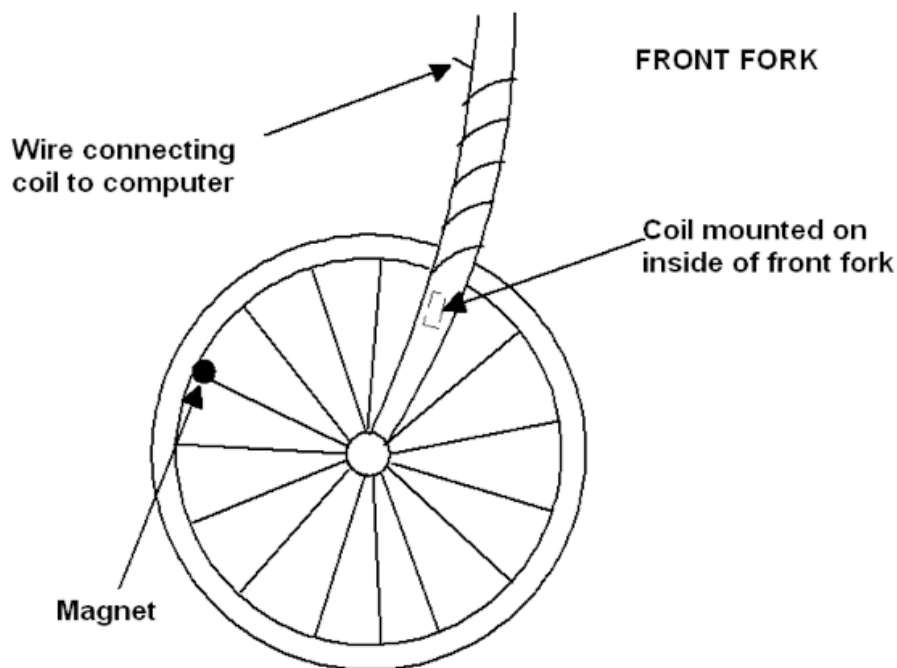

- a) Briefly describe in terms of electromagnetic induction how the bicycle's speed is measured. [3 marks]
- b) Is it necessary to mount the magnet on the circumference of the wheel, as shown in the diagram, for the system to function properly? Explain your answer. [2 marks]

End of Section One

This page has been left blank intentionally and can be used as additional Working Space

This section has **eight (8)** questions. You must answer **all** questions. Write your answers in the space provided.

Suggested working time for this section is 95 minutes.

Question 1

[14 marks]

The diagram below shows a glass globe containing a heated filament that emits electrons by thermionic emission. Initially, the space inside the globe is a vacuum. The electrons are attracted to, and then pass through, a hollow conical anode. This forms a narrow beam of electrons.

The electron beam then enters a region of uniform magnetic field. The magnitude of this field can be changed.

This device can be used for a range of experiments.

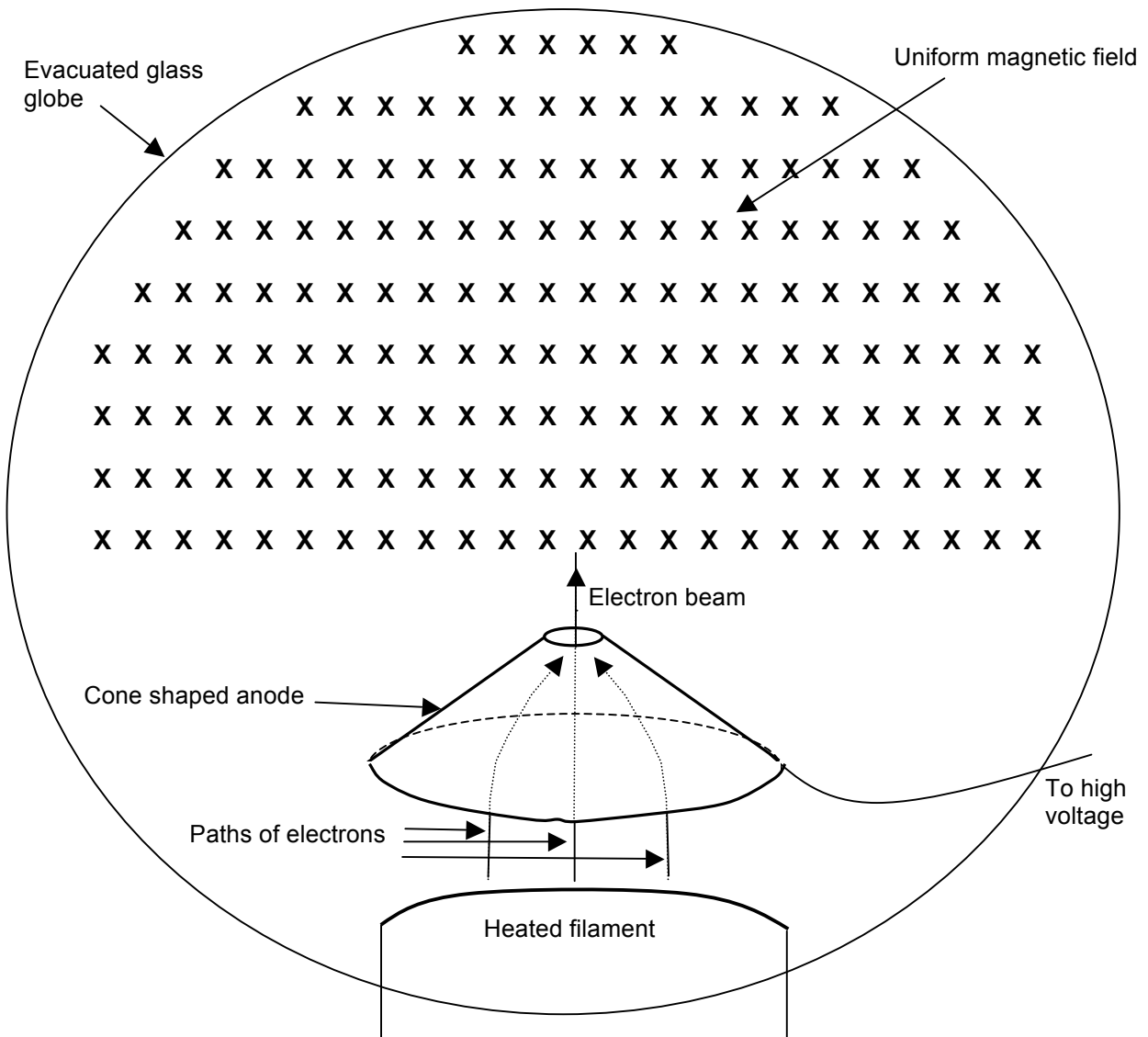

(a) Is the anode positively or negatively charged? Explain your answer. (2 marks)

(b) Show clearly on the diagram the trajectory of the electron beam whilst in the uniform magnetic field. (2 marks)

(c) Using the equation $F = Bqv$ and an equation for circular motion, show that $r = \frac{mv}{Bq}$.
Show your working. (3 marks)

(d) One experiment using this apparatus gives the following experimental measurements:

electron speed = $2.00 \times 10^7 \text{ m s}^{-1}$
magnetic field strength = $1.20 \times 10^{-3} \text{ T}$
radius of electron path = 10.0 cm.

Use **these** values to calculate the charge to mass ratio $\frac{e}{m}$ for an electron. (3 marks)

(e) If the glass globe is filled with neon gas, a glowing pink ring appears within the globe when the electron beam is turned on. Explain why this glowing ring appears. (3 marks)

(f) Suggest how the colour of the glowing ring could be changed. (1 mark)

Question 2

[14 marks]

The diagram below shows some of the possible electron energy levels in a hydrogen atom. The ionisation energy for a hydrogen atom is 13.6 eV.

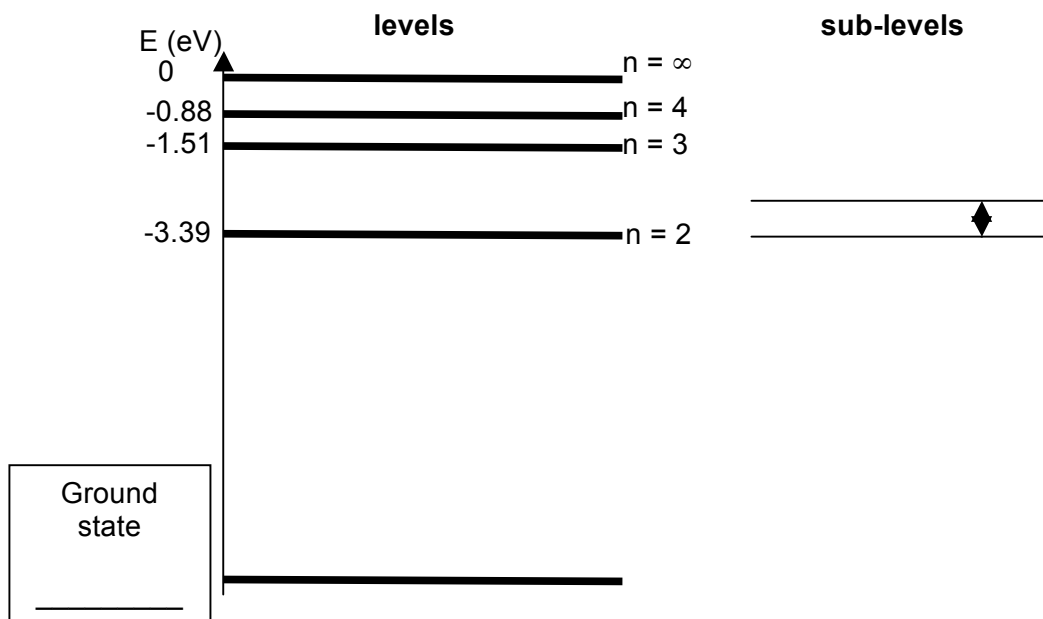

(a) Mark the value of the ground state of hydrogen in the box labelled 'ground state'. (1 mark)

(b) Explain what is meant by the term 'ionisation energy'. (2 marks)

(c) Light from a hydrogen discharge tube can be seen as a line emission spectrum. Using a labelled diagram, describe what a line emission spectrum looks like. (3 marks)

The diagram above is based on the Bohr model of the atom, which is the simplest model of the hydrogen atom. In more physically accurate (and more complex) models the $n = 2$ energy level is split into two sub-levels. An electron making a transition between these sub-levels emits a photon with a wavelength of 21 cm.

(d) Calculate the energy difference (in eV) between the two $n = 2$ sub-levels. (3 marks)

This 21 cm wavelength in the hydrogen spectrum is used by radio astronomers to measure the velocities of stars and galaxies.

(e) Describe the difference you would expect to see between a hydrogen spectrum emitted by a galaxy that is not moving toward or away from our galaxy, and a hydrogen spectrum emitted by a galaxy moving away from our own. (2 marks)

(f) How does your answer to (e) provide evidence for the Big Bang model of the formation of the Universe? (3 marks)

Question 3**[12 marks]**

Plucky McClintock likes to jump over buses on her trail bike. In an exhibition one day she drives her motorcycle up a ramp, over a bus and lands safely on the ramp at the other side. The left hand ramp has an incline of 42° and when she takes off the centre of gravity of her and her machine is 2.4 m above the ground. Her speed at this point is 45 km h^{-1} .

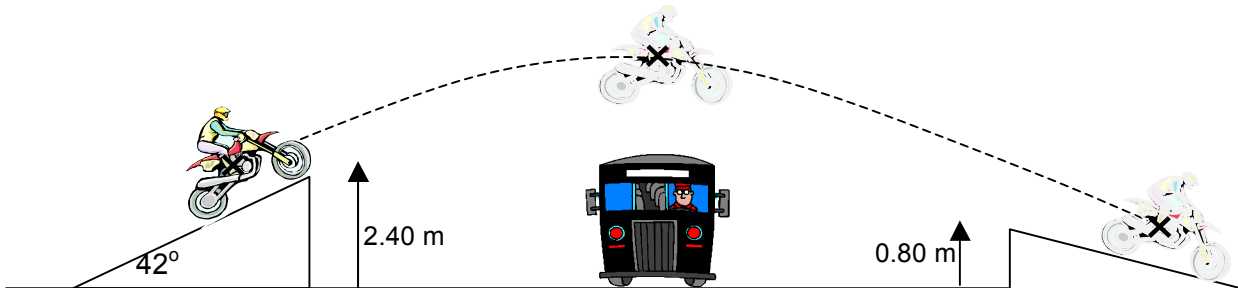

a) What is the vertical component of Plucky's take off velocity? [2 marks]

b) What is the maximum height reached by Plucky and her bike (centre of gravity) above the ground? [3 marks]

Plucky and her machine land on another ramp at the other side of the bus, at which point the centre of mass of the combination is 0.80 m above the ground.

c) What is the vertical speed of the motorcycle when Plucky lands? [3 marks]

d) Calculate the how far away horizontally the motorcycle is from its take-off position when it lands. [4 marks]

Question 4

[13 marks]

Olivia decides to go fishing one day with her new rod and tripod. She sits on the banks of the Swan river and sets the 900 gram rod up with the tripod close to the bank and a cable at the left hand end anchored into the ground with a tent peg. The centre of mass of the rod is 1.00 m from the left hand end of the rod. She has not caught a fish yet!

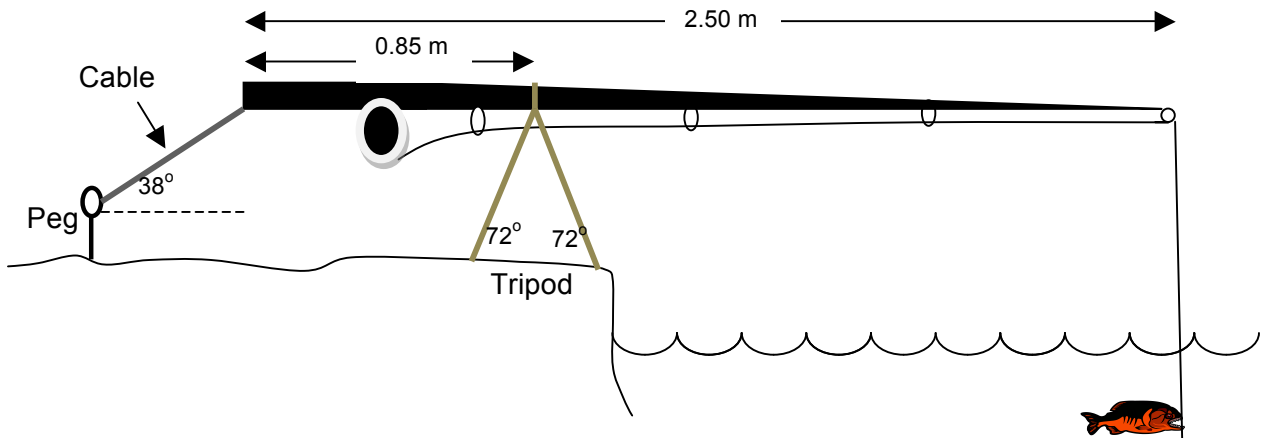

a) Explain why Olivia needs to secure the end of the rod with a peg and cable. [2 marks]

b) Draw in and name all the forces acting on the rod, using arrows to show their directions. [2 marks]

Olivia eventually manages to hook a 1.50 kg fish on the end of her line.

c) Calculate the **vertical** force that *cable* has to exert to keep the rod in a horizontal position. [3 marks]

d) If the cable makes an angle of 38° to the ground, calculate the total force of tension needed in the cable when the fish is caught. [2 marks]

e) If the legs of the tripod make an angle of 72° to the ground, calculate the compressive force in each leg of the tripod when the fish is on the end of the line. [4 marks]

Question 5

[9 marks]

A portable AC generator is hired by an Outback cricket team to power the spotlights needed for a night game. The cable linking the generator to the lights has a length of 700 m and a total resistance of 7.50Ω . The lights consume an electrical power of 2.40 kW at a frequency of 50.0 Hz and an AC voltage of 240 V when they are operating at full power.

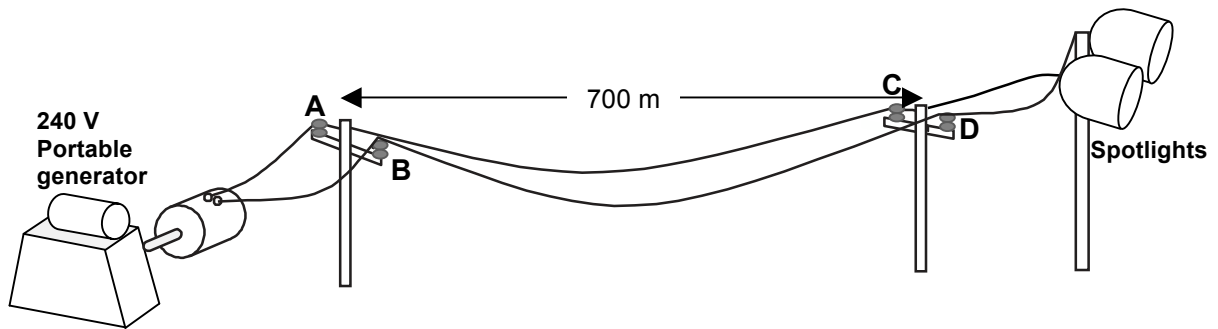

When testing the system a voltmeter is connected across points A and B and the generator started up.

a) Which of the graphs below would display the voltage across points A and B as the generator is starting up and reaching full speed? (circle the correct answer). [1 mark]

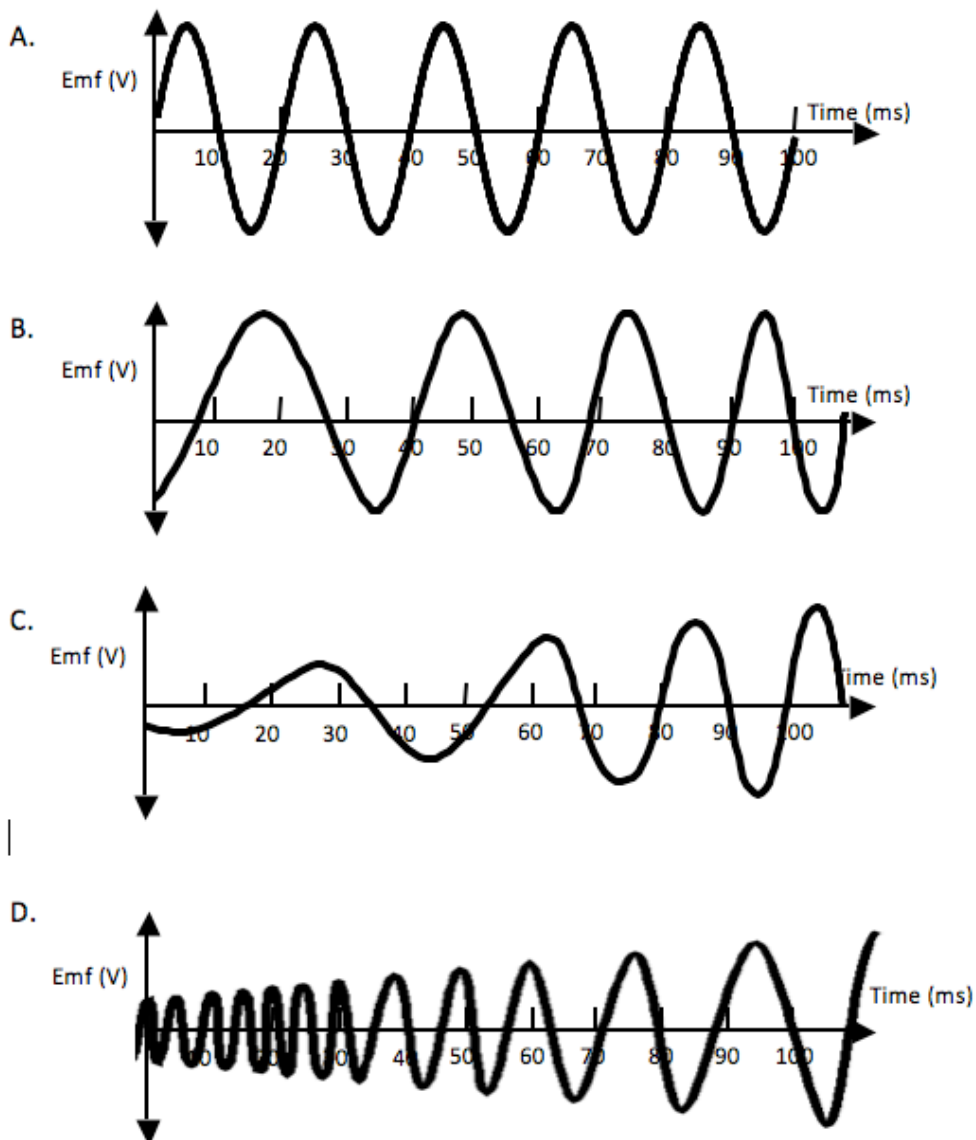

b) When the technicians test the voltage in the powerlines across points C and D they find that the voltage is no longer 240 V. Calculate the voltage delivered to the spotlights at CD. [3 marks]

c) What is the power loss in the wires? [2 marks]

When the lights are turned on they appear much dimmer than they should be and the technicians realise that there is a design fault in the system. They remedy this by installing transformers at points AB and CD in the cables.

d) Explain how this modification produces brighter lights at the cricket ground. [3 marks]

Question 6

[12 marks]

The figure below represents a DC motor whose coil is initially stationary.

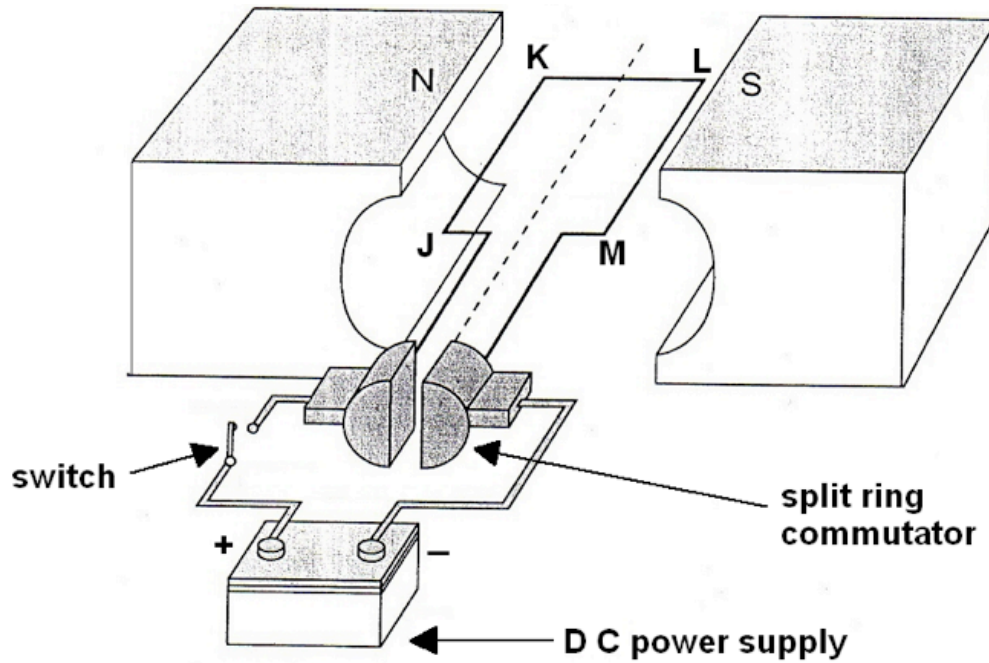

(b) In which direction, clockwise or anticlockwise will the motor rotate when the switch is closed? (1 mark)

(c) Explain your answer to 3(b). (2 marks)

The figure below represents an **alternator** consisting of a rectangular coil with sides of 0.15 m x 0.20 m and 1200 turns, rotating in a magnetic uniform field. The magnetic flux through the coil in the position shown is 2.5×10^{-4} Wb.

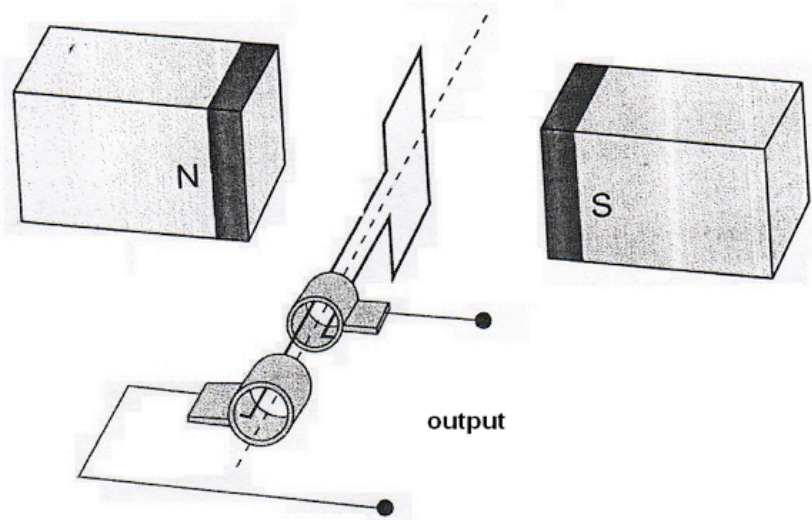

(d) Calculate the magnitude of the magnetic field strength. (3 marks)

(e) If the coil rotates **half** a revolution from its starting position in 0.03 s, calculate the magnitude of the average induced emf in the coil in this time. (3 marks)

(f) How could you modify the alternator to increase the magnitude of the emf? (3 marks)

Question 7**[12 marks]**

A crude musical instrument can be made by tying several lengths of hollow metal tube together, as shown in the diagram below. When India gently blows across the tops of the tubes, musical notes are produced.

For all parts of this question assume that India blows with the same strength.

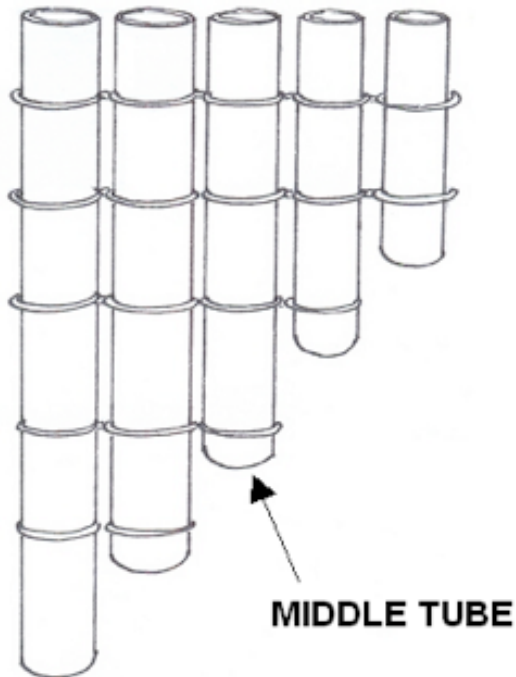

(a) If all the tubes are of equal diameter, which tube would you expect to produce the note with the highest fundamental frequency? Explain your answer. (2 marks)

(b) If the fundamental resonant frequency of the middle tube is 440 Hz and the speed of sound in the tube is 346 m s^{-1} , calculate the length of the tube. (2 marks)

(c) If India blocked the bottom end of the middle tube would you expect it to produce the same fundamental note as the open tube? Explain your answer. (3 marks)

(d) Determine the fundamental frequency of the note produced by the middle tube when it is closed at one end. (2 marks)

(e) The instrument relies upon standing waves being set up in the tubes. State the conditions that need to exist for standing waves to be produced in an air column. (3 marks)

Question 8

[9 marks]

A satellite provides information about the receding glaciers on the Earth's surface. It has a mass of 395 kg and is in a circular orbit of radius 1.45×10^4 km. By orbiting for 12 days it can map most of the Earth's glaciers.

a) Calculate the orbital speed of the satellite. (3 marks)

b) At what **altitude** above the Earth is the satellite orbiting? (2 marks)

c) List the force(s) that keep the satellite in its stable circular orbit. (1 mark)

d) On the diagram below draw one or more **labelled** arrows to show the direction of the force(s) on the satellite as it orbits the Earth. (1 mark)

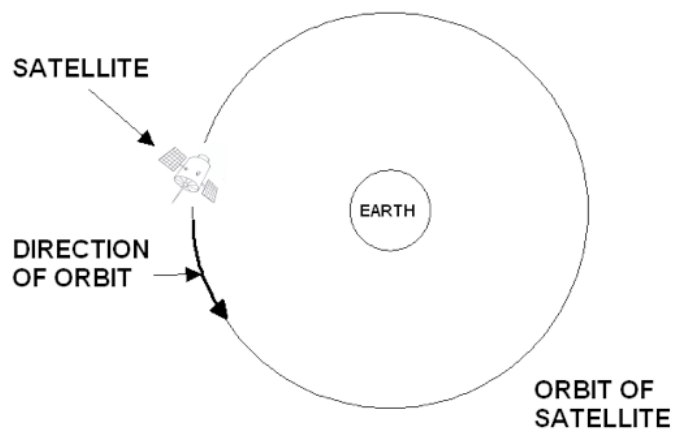

e) Would you expect this satellite to be in a geostationary orbit about the Earth? Explain your answer. (2 marks)

This page has been left blank intentionally and can be used as additional Working Space

Section Three: Comprehension & Data Analysis**20% [36 Marks]**

This section contains **two (2)** questions. You must answer both questions. Write your answers in the space provided.

Suggested working time for this section is 40 minutes.

Question 1**[18 marks]****Hubble's Law**

When a source of waves moves, the waves it emits change frequency relative to a stationary observer. This applies to both transverse and longitudinal (sound) waves. As a car moves away from you the frequency of the sound you hear is lower than the frequency it is emitting. A similar effect using radar waves is used by police to measure the speed of cars.

Thus if a source of electromagnetic waves such as a star is moving away from an observer on Earth then the frequencies of the lines in the star's emitted electromagnetic spectrum are shifted to lower values. This is known as red shift.

In 1920, Edwin Hubble measured the red shifts of several galaxies and discovered that most galaxies are moving away from the Earth, suggesting that the Universe is expanding. Hubble also found that the further away a galaxy is, the larger its red shift; that is, the faster it is moving.

The following data together with the associated errors were recorded by Hubble at Mount Wilson in California in the 1940s using an optical telescope.

Object name	Speed of recession ($\times 10^4 \text{ km s}^{-1}$)	Distance ($\times 10^6 \text{ light years}$)
Virgo	0.2 ± 0.1	10.2
Corona Borealis	2.4 ± 0.2	400
Hydra	6.2 ± 0.3	1100
Kip	4.8 ± 0.2	900

- (a) Graph these data on the graph paper below, including error bars. Plot recession speed (y -axis) against distance (x -axis) and draw a line of best fit. (5 marks)

If you wish to have a second attempt at this item, the grid is repeated on page 36. Indicate clearly on this page if you have used the second grid and cancel the working on the grid on this page.

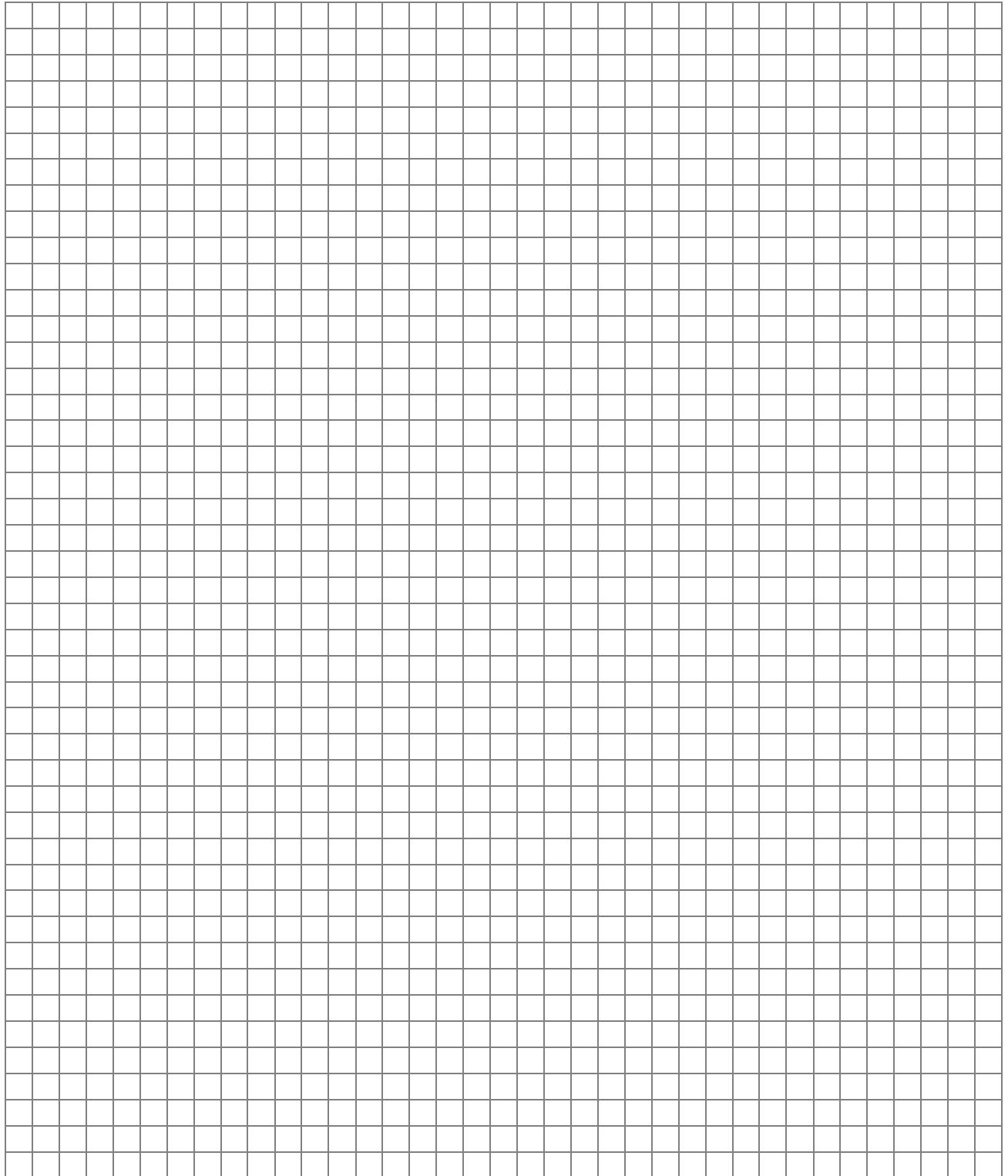

- b) Use the graph to predict the recession speed of a galaxy that is 710×10^6 light years from Earth. Clearly indicate on the graph how you have done this. (2 marks)

- (c) Hubble's Law can be stated as

$$v_{\text{galaxy}} = (H_o)(\text{distance})$$

where the term H_o is called Hubble's constant.

Use your graph to calculate a value for H_o . Clearly indicate on the graph how you have done this. Take care with the units! (4 marks)

- (d) The shift in wavelength $\Delta\lambda$ due to recession of a spectral line of wavelength λ is given by the formula

$$v_{\text{galaxy}} = \left(\frac{\Delta\lambda}{\lambda} \right) c \quad \text{where } c \text{ is the speed of light, } 3 \times 10^8 \text{ m s}^{-1}.$$

A line in the spectrum of ionised calcium has wavelength 393.3 nm when measured in the laboratory. When similar light from the elliptical galaxy Carrara is measured its wavelength is 401.8 nm. Determine the recession speed of Carrara. (3 marks)

- (e) Edwin Hubble could estimate the age of the Universe from his data by calculating the time for which one of the galaxies has been receding. Determine Hubble's value for the age of the Universe by using the data for Corona Borealis given in the table on page 35. Take care with the units! (4 marks)

The Australian Synchrotron

Figure 1

1. electron gun
2. linac
3. booster ring
4. storage ring
5. beamline
6. end station

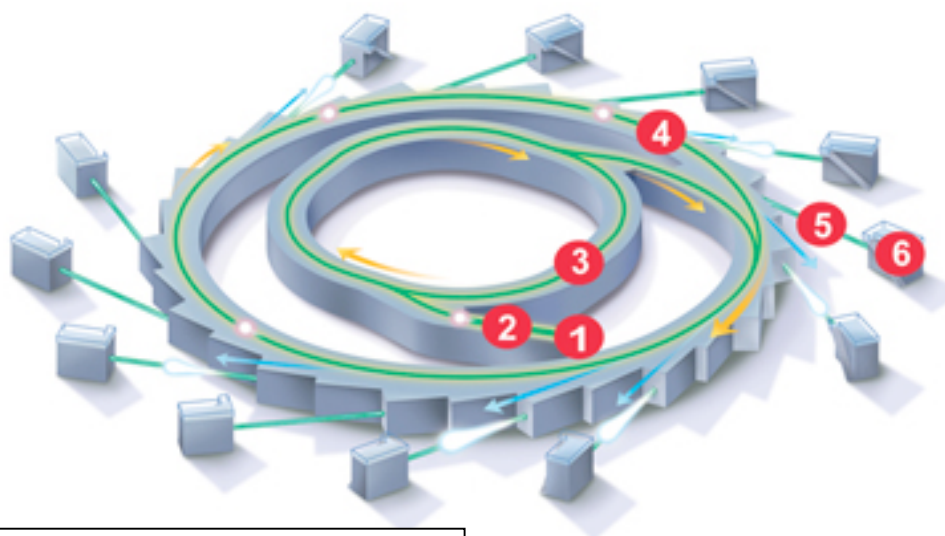
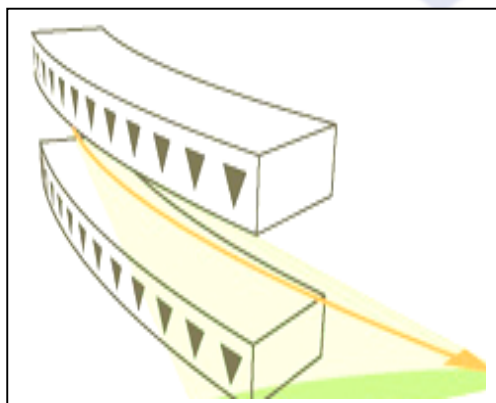

Figure 2

*Illustration of a bending magnet.
At each deflection of the electron path
a beam of light is produced. The effect
is similar to the sweeping of a search
light.*

Synchrotron light is the electromagnetic radiation emitted when electrons, moving at velocities close to the speed of light, are forced to change direction under the action of a magnetic field. The electromagnetic radiation is emitted in a narrow cone in the forward direction, at a tangent to the electron's orbit.

Synchrotron light is unique in its intensity and brilliance and it can be generated across the range of the electromagnetic spectrum: from infrared to x-rays.

Synchrotron light beamline specifications:

Source: 1.9 Tesla wiggler magnet

Available energy range: 4 - 50 keV

Diameter of storage ring: 16 m

Beam size at sample (horizontal x vertical) is 0.5 mm (h) x 0.2 mm (v)

Photon flux at sample > 5×10^{12} photons / second

Features of the synchrotron

- x-ray imaging which allows much greater contrast from weakly absorbing materials such as soft tissue than is possible using conventional methods
- two and three-dimensional imaging at high resolution
- lower tissue doses than conventional x-ray methods, making longitudinal studies (serial imaging) possible
- tuneable beam energy, which enables the imaging of specific elements with very high sensitivity

Examples of uses of the synchrotron:

- Studies of lung function and development are assisting the development of better asthma treatments and improved clinical practice options for neonatal care
- Measurements of bone density and porosity, enhanced mammography techniques, and studies of nerve cell regrowth to assist the development of biopolymers to treat spinal injuries
- The contrast mechanisms used to visualise soft tissues can also be used to study structures inside plants, and are of particular interest for investigating drought- and salt-tolerant plants to develop more efficient crops for Australian conditions

The observation that normal tissue has remarkable resistance to cell death when irradiated with very thin X-ray beams has led to the development of microbeam radiation therapy (MRT). Dr Peter Rogers and colleagues from the Monash Medical Centre and Monash Centre for Synchrotron Science have found that normal tissue tolerates doses up to 100 times greater than those permitted in treatments using conventional methods, and that entire tumours are destroyed when only 10 per cent of their volume has been irradiated. These beams can be captured and focussed to a specific wavelength appropriate for a particular technique.

Questions

- a) Draw in the direction of the magnetic field lines in Figure 2. [2 marks]
- b) Assuming that the electrons are accelerated to close to the speed of light, this would take them about 1.4 million times around the outer storage ring in one second. However, in the *frame of reference* of an electron in the ring, it would appear that they had travelled round many more times than this in the same amount of time. Explain this in terms of Einstein's Special Theory of relativity. [3 marks]
- c) Why is synchrotron radiation preferable to normal x- or gamma ray therapy in the treatment of cancers? [2 marks]

- d) One of the features of synchrotron radiation is that the location of specific elements can be accurately located within the body. Give an example where this ability could be valuable for use in Forensic Science. [2 marks]
- e) By equating the 50 keV electrical energy given by the Linac with the kinetic energy, calculate a value for the velocity of the electrons emerging from it. [3 marks]
- f) The final energy of photons colliding with the target sample is around 4×10^{-14} J. What would the wavelength of the emerging electromagnetic waves be? [3 marks]
- g) From the beam size data given, calculate a value for the power absorbed per square metre when 5×10^{12} photons strike the target per second. [3 marks]

END OF EXAM ☺

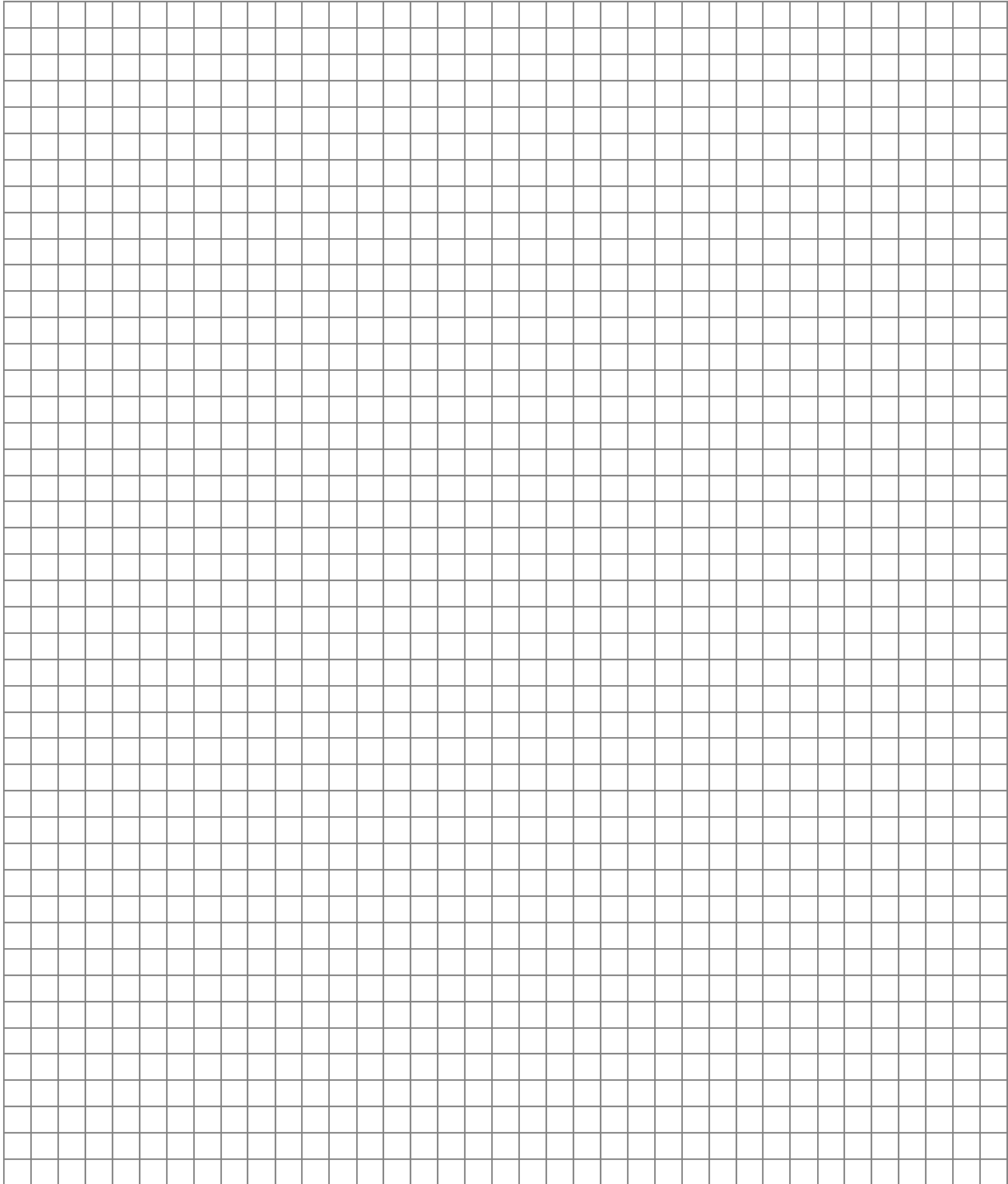

ACKNOWLEDGEMENTS

Question 1C Astronomical data source: Serway, R., Beichner, R., & Jewett, J. (2000). *Physics for scientists and engineers* (5th ed.). Philadelphia: Saunders College Publications, p. 1541.